

MOHRLANG MIXER FEEDER

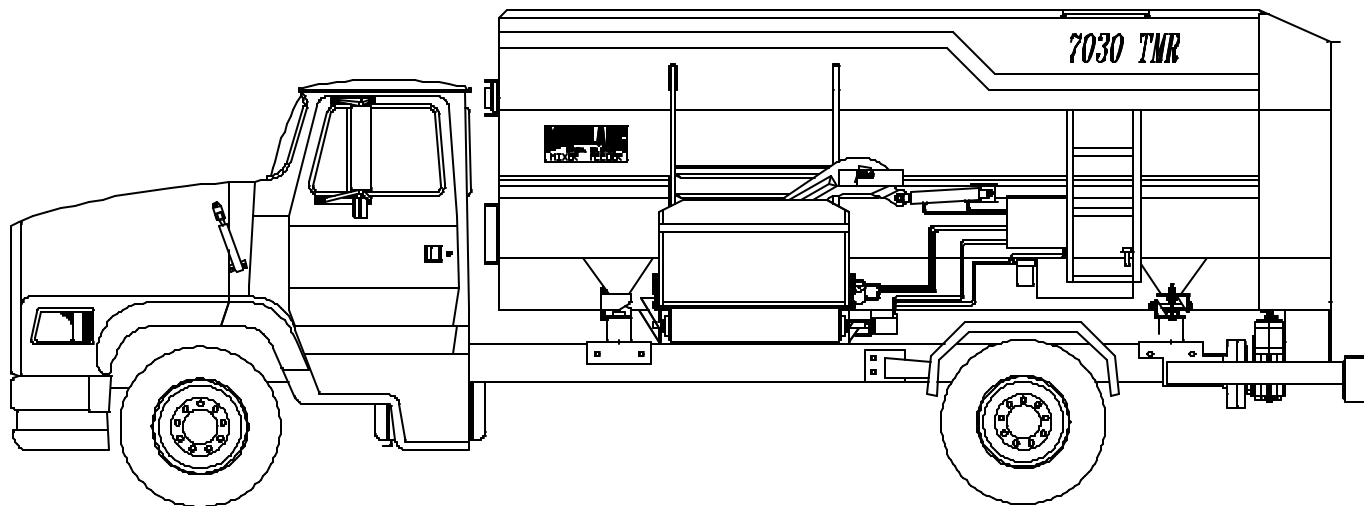

***MODELS: 6030, 7030,
8030 & 9030***

**OPERATORS MANUAL
FOR
TRUCK MOUNT
TRAILER MOUNT STATIONARY MOUNT**

MOHRLANG
BRUSH, COLORADO

COMPLEMENT
YOUR
CATTLE FEEDING OR DAIRY OPERATION
WITH THESE
QUALITY MOHRLANG PRODUCTS

MANURE SPREADER

CONVEYORS

BELT
CHAIN
REVERSE DRAG

HEAVY DUTY AUGERS

**STATIONARY
ROUGHAGE BOXES**

**ELECTRONIC SCALES
and
CUSTOM FABRICATION**

MOHRLANG

**BRUSH, COLORADO
MIXER FEEDER**

THIS WARRANTY MUST BE REGISTERED WITHIN 15 DAYS

The MOHRLANG warranty is valid only after the "QUALITY CONTROL & SAFETY CHECK LIST" has been completed by the Dealer and signed by the Owner, or his representative, and the Dealer, or his representative, and the completed form is received at the plant.



**PO Box 544
Brush, Colo. 80723
970-842-5161**

Model Serial No. _____ Delivery Date ____/____/____
Type: Truck Trailer

Owner _____

Address _____

City _____ State _____ Zip _____

Phone No. (____) _____

Usage: Commercial Farmer Other _____

Dealer _____

Address _____

City _____ State _____ Zip _____

I hereby acknowledge: (1) The completion of the "Quality Control and Safety Check List" and that I retained a copy thereof, together with the Owner's Manual; (2) that I have read and understand the nature extent, limitations and exclusions of the manufacturer's warranty and; (3) that there were and are no other representations or warranties, either expressed or implied by anyone.

"QUALITY CONTROL AND SAFETY CHECK LIST"

- Check all structural welds for appearance.
- Check all bolted connections for tightness.
- Check rear drive enclosure for proper sprocket alignment and correct chain tension.
- Check bearings for alignment, tightness of locking collars and proper placement of bearing stops.
- Check bearings for lubrication.
- Check rear door for proper latch tension and fit. Correct any oil leaks.
- Check hydraulic reservoir for proper fluid level and leaks.
- Check hydraulic filter for proper installation.
- Check hoses for correct clearance and fitting for leaks.
- Check main drive shaft for proper installation and clearance.
- Check U-joints for timing and installation.
- Check Gear Boxes for installation and oil level.
- Check frame/box mounting point for proper installation.
- Check for trash or foreign articles in conveyor.
- Check oil level of rear drive enclosure.

RUN MIXER AND CHECK THE FOLLOWING:

- Check for vibration & run out of drive lines.
- Check chain for vibration.
- Check for free operation of discharge conveyor.
- Check chute and door actuation.
- Check augers for straightness, timing and clearance.
- Check mixer, observing that all safety decals and safety shields are in place.
- Check external paint for appearance.
- Check clearance and marker light installation and operation.
- Operator has been instructed in operation, maintenance and safety precautions.

Owner _____ Dealer _____

MOHRLANG COPY

TABLE OF CONTENTS

OPERATION AND MAINTENANCE

SAFETY FIRST.....	1
INTRODUCTION.....	2-3
BALED ALFALFA HAY MIXING TMR.....	4
GENERAL SPECIFICATION.....	5
TRUCK SPECIFICATION.....	6-7
TRAILER SPECIFICATION.....	8-9
STATIONARY SPECIFICATION.....	10-11
OPERATION.....	12
TROUBLESHOOTING.....	13
MAINTENANCE.....	14
LUBRICATION SCHEDULE.....	15

PARTS BREAK DOWN AND ILLUSTRATIONS

LOAD CELL & SCALE BRACKET.....	16-17
CONVEYOR CHAIN DISCHARGE.....	18-19
CONVEYOR AUGER DISCHARGE.....	20-21
DISCHARGE CHUTE.....	22-23
DISCHARGE GATE.....	24-25
REAR DRIVE.....	26-29
FRONT PARTS.....	30-33
DRIVE TRAIN.....	34-36
GEAR BOX GR1600.....	37-39
GEAR BOX M-625.....	40-42
HYDRAULIC SCHEMATIC (TRUCK MOUNT).....	43-44
TRAILER BREAK DOWN.....	45-46
TANDEM TRAILER ASSEMBLY.....	47-48
HYDRAULIC SCHEMATIC (TRAILER MOUNT).....	49-50
REVOLUTION PER MINUTE.....	51
U-JOINT ALIGNMENT.....	52
BELT TENSION GUIDE.....	53
ELECTRIC VALVE SCHEMATIC.....	54-55
SCALE INDICATOR.....	56-57



Limited Warranty

The Mohrlang Mfg., Inc., herein referred to as "Mohrlang", warrants products of its manufacture to be free from defects in material and workmanship, under normal use and service, for a period of 6 months or 1000 hours of usage, whichever comes first. This limited warranty is effective only if the equipment or apparatus is used as directed, is not subjected to misuse, negligence or accident, and is not altered, treated or repaired by someone other than Mohrlang or its designee. Items not manufactured by Mohrlang shall bear only the limited warranties offered by their respective manufacturers.



The exclusive remedy for breach of this warranty shall be to give Mohrlang written notice thereof and to request a Returned Goods Authorization. Upon receipt of the Returned Goods Authorization, the buyer will return the non-conforming material to Mohrlang F.O.B. its plant within thirty days after the buyer has received the Returned Goods Authorization. Thereupon Mohrlang at its own election shall repair or replace the same or repay the price thereof. No proximate, incidental, consequential or other damages shall be recoverable.

Mohrlang shall not be liable for consequential damages or contingent liabilities including; but not limited to, loss of life, personal injury, loss of crops, loss due to fire or water property damage, and consequential trade or other commercial loss arising out of the failure of Manufacturer's product.

MOHRLANG MAKES NO WARRANTIES OF FREEDOM FROM PATENT INFRINGEMENT, OF MERCHANTABILITY, OF FITNESS FOR A PARTICULAR PURPOSE OR ARISING FROM A COURSE OF DEALING OR USAGE OF TRADE OR OTHER LIKE OR DIFFERENT EXPRESS OR IMPLIED WARRANTIES EXCEPT AS MADE ABOVE.

MOHRLANG MFG., INC.
Brush, Colorado 80723





Mixer-Feeder Gear Box GR1600 Limited Warranty

Mohrlang Mfg., Inc., herein referred to as "Mohrlang", warrants th Model GR1600 Gear Box to be free from defects in material and workmanship, under normal use and service, for a period of 24 months from date of purchase. This limited warranty is effective only if the equipment or apparatus is used as directed, is not subjected to misuse, negligence or accident, and is not altered, treated or repaired by someone other than Mohrlang or its designee. Items not manufactured by Mohrlang shall bear only the limited warranties offered by their respective manufacturers.

The exclusive remedy for breach of this warranty shall be to give Mohrlang written notice thereof and to request a Returned Goods Authorization. Upon receipt of the Returned Goods Authorization, the buyer will return the non-conforming materail to Mohrlang F.O.B. its plant within thirty days after the buyer has received the Returned Goods Authorization. Thereupon Mohrlang at its own election shall repair or replace the same or repay the price thereof. No proximate, incidental, consequential or other damages shall be recoverable.

Mohrlang shall not be liable for consequential damages or contingent liabilities including; but not limited to, loss of life, personal injury, loss of crops, loss due to fire or water property damage, and consequential trade or other commercial loss arising out of the failure of Manufacturer's product.

MOHRLANG MAKES NO WARRANTIES OF FREEDOM FROM PATENT INFRINGEMENT, OF MERCHANTABILITY, OF FITNESS FOR A PARTICULAR PURPOSE OR ARISING FROM A COURSE OF DEALING OR USAGE OF TRADE OR OTHER LIKE OR DIFFERENT EXPRESS OR IMPLIED WARRANTIES EXCEPT AS MADE ABOVE.

MOHRLANG MFG., INC.
Brush, Colorado 80723

